



The Timken Company

4500 Mt Pleasant St. NW

N. Canton, OH 44720

Phone: (234) 262-3000

E-Mail: [CustomerCAD@timken.com](mailto:CustomerCAD@timken.com) • Web site: [www.timken.com](http://www.timken.com)

Housing – Bearing – Seal SNT 524-620 - 22224K - TSNG524, SNT/FSNT Taper Bore

Plummer Block Mounted Bearings

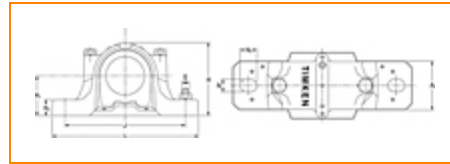

[Types of Components](#) | [Housing](#) | [Bearing](#) | [Dimensions](#) | [Specifications](#)

## Types of Components

Housing	SNT 524-620
Bearing	22224K
Locating Rings (width x OD)	SR215X14
Seal Type	Double Lip
Seal	TSNG524
Adapter Sleeve <sup>1</sup>	H3124
Locknut	KM24
Lockwasher	MB24
End Cover <sup>2</sup>	EC524-620



## Housing

Material	Cast Iron
Housing Mass	26.5 Kg
Bolt Qty	2

## Bearing

Cage Type	EJ
C1 Dynamic Load Rating	647000
C0 Static Load Rating	772000
Max Oil Speed	3200
Max Grease Speed	2600

## Dimensions

Shaft Diameter d	110 mm
A	185 mm
A1	120 mm
G	M24
H	271 mm
H1	140 mm
H2	45 mm
J	350 mm
Jmax	356 mm
Jmin	344 mm

<b>L</b>	410 mm
<b>N</b>	26 mm
<b>N1</b>	32 mm

## Specifications

<b>UPC Code</b>	999999999
<b>Alternate Part Name</b>	SNT524-620 - 22224K - TSNG524

<sup>1</sup> Purchase the Adapter Sleeve separately

<sup>2</sup> Two seals are required for a thru shaft application. One end cover can be used if application is not a thru shaft design. In this case, only one seal is required.

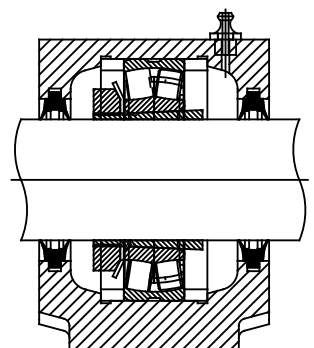
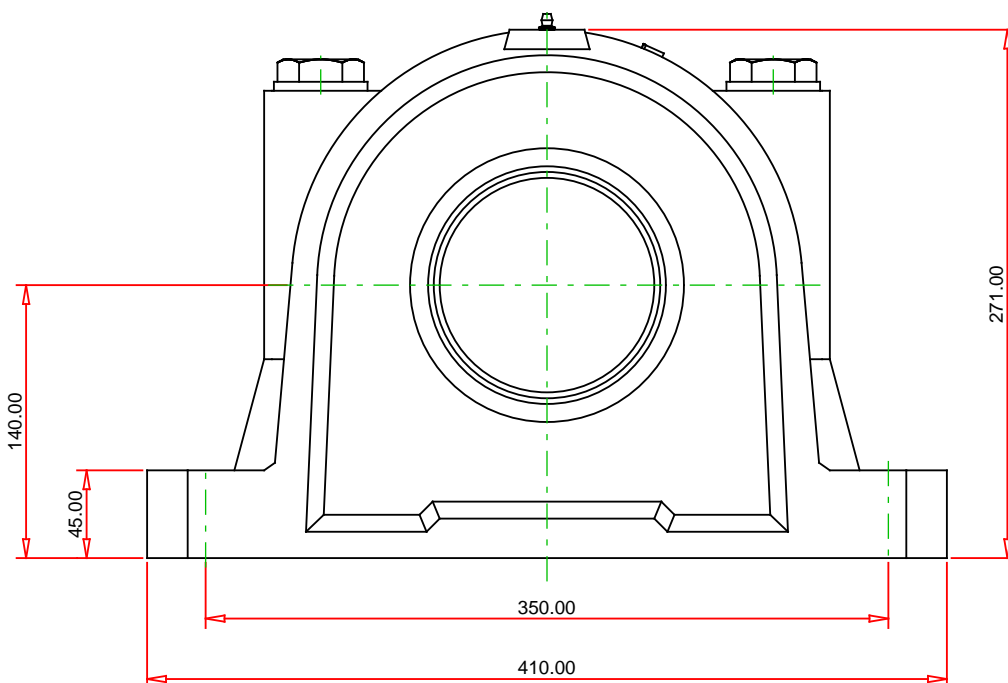
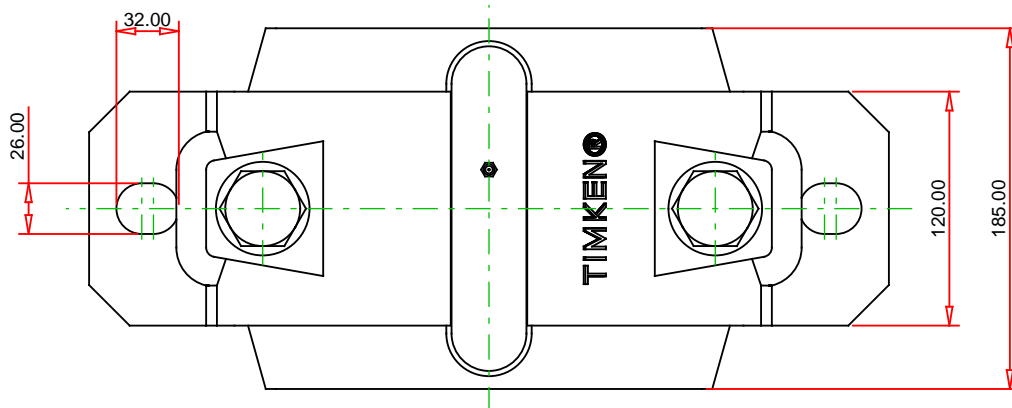

Note: Section View not to Scale

METRIC UNITS

Housing	SNT 524-620
Bearing	22224K
Seal (Quantity 2)	TSNG524
Seal Type	Double Lip
Locating Ring (Quantity 2)	SR215X14
Adapter Sleeve	H3124
(includes 1 sleeve, 1 locknut and 1 lockwasher)	

**TIMKEN**<sup>®</sup>

**SNT 524-620 - 22224K - TSNG524**  
SNT/FSNT Taper Bore Plummer Block Mounted Bearings

**THE TIMKEN COMPANY**  
NORTH CANTON, OHIO USA

C1 Dynamic Load Rating (2 rows)	647000 N
C0 Static Load Rating	772000 N
Max Oil Speed	3200 RPM
Max Grease Speed	2600 RPM
Material	Cast Iron

Every reasonable effort has been made to ensure the accuracy of the information contained in this writing, but no liability is accepted for errors, omissions or for any other reason.

**FOR DISCUSSION ONLY**